

OpenRISC - Alena

RISC-CPU based industrial embedded computer with CAN port



Art No. 6805
www.vsc.com.de/6805.htm



The OpenRISC-Alena is an ARM9-based RISC industrial embedded computer. The great variety of interfaces like LAN, C/F, USB, I²C, serial interface, CAN interface, digital I/O makes it easy to connect various industrial devices to the OpenRISC. Because of CAN and RS485 options the Alena is good in monitoring field bus systems.

Compact dimensions and DIN Rail mounting capability make the OpenRISC to a space saving and flexible mounting industrial computer. It is feasible to be installed even in space limited environments. The internal microSD slot protects the system software against accidentally removal.

Due to RISC based architecture the OpenRISC has very small power consumption, so fanless heat dissipation is possible. Working in a wide temperature range from -10°C up to 65°C the OpenRISC can be applied in under harsh industrial conditions. Therefore the OpenRISC is downright designed for industrial automation.

The embedded computer runs full-featured Debian GNU/Linux on ARM operating system Kernel 2.6. With Debian's repository database it is easy to install and update the free software on the OpenRISC. The OpenRISC is capable to act directly as software development host, WEB, Mail, Print and Database server or as a desktop computer with X11 windows manager and many more.

FEATURES

- ARM9 166MHz industrial processor
- 64MB SDRAM, 4MB Flash
- 1 x microSD-Reader (internal 2GB)
- 1 x CF-Slot (True IDE mode)
- 2 x USB 2.0 Host, 1 x CAN Port
- 2 x Serial Ports RS232/422/485
- 2 x Serial Ports RS232
- 2 x Fast Ethernet Auto-MDI(X)
- 4 x Digital-I/O, 2 x optical isolated input
- 2 x relay output
- 1 x I²C, 1 x MiniPCI-Slot (optional)
- 1 x Console Port

Variety of interfaces

Many interfaces, like LAN, USB, I²C, serial ports RS232/422/485, digital I/O and MiniPCI-Slot, make it easy to connect various industrial devices to the OpenRISC systems.

Ready to Run, up to date

OpenRISC systems run full featured Debian GNU/Linux on ARM operating system including all device drivers for peripherals.

Linux kernel 2.6 boots from CF card or the internal microSD card. This kernel has better support for USB devices, handles the Watchdog Timer of OpenRISC systems, and provides the udev file system for devices. Many other new features can be read in the public Linux documentation.

High Performance

ARM9 32-bit RISC CPU (166MHz) & 64MByte SDRAM memory allow the OpenRISC Alena to provide high performance for data processing.

Wireless Capability

Equipped with one MiniPCI Slot for WLAN, Video-Capture expansion.

APPLICATION

One Application field for OpenRISC embedded computers is intelligent networking of the production tools, such as NC-Machines, PLC-Controllers and I/O controllers. These devices can be usually accessed only via RS232/422/485 or over Digital I/O. Field busses may be attached to RS485 or CAN.

OpenRISC Alena directly interfaces these devices via serial ports or Digital-I/O, at the same time via Ethernet it acts as a Gateway to higher computer instances, such as monitoring and/or control workstations. Without contact to such workstations OpenRISC systems can supply the manufacturing devices with production data on demand, download their programs, can buffer data from/to those devices, run maintenance tests or perform data protocol conversions.

The internal SD reader as mass storage for boot can separate the operating system and application or configuration files from production data such as protocol files or NC programs on the Compact Flash card. The system is protected then against accidentally removal. Administrators are free to decide for their configuration, and use the Compact Flash slot to upload new data and configurations, where a network is not available.



Hardware Specifications

System

Processor : ARM9 32-bit RISC CPU, 166MHz
Memory : 64MB SDRAM
Flash : 4 MB, 2GB microSD
MicroSD-Reader : 1 x internal as boot device, 7 MB/s SD 2.0 / SDHC
CF Slot : Type II, True IDE mode (accepts MicroDrives)
LAN : 2 x Fast Ethernet Auto-MDI(X)
USB : 2 x USB 2.0 as Host
Expansion Slot : MiniPCI (for WLAN)
Console Port : RS232, up to 115200bps
I²C : Max. 330kHz
Time : Real time clock with battery backup (CR2032 in clip)
Other : RTC, Buzzer, Watchdog Timer

Digital I/O x 8

Input/Output : 4 Input/Output signals
Signal configuration : Signal direction individually configurable as input/output
Electrical : TTL level, 32mA
Input : 2 optical isolated Input signals
Electrical : Opto-coupler with pull-up resistor
IRQ : Maskable IRQ for input signals
Output : 2 Relay Output signals, dual function
Electrical : Contact Rating: 1A 30VDC / 0.5A 125VAC
 Switching Power: 30W (DC) / 62.5VA (AC)
Connector type : Terminal block

Serial Interface

Serial Port : Highspeed UART 16C950, 128 Byte FIFO
 2 x RS232/422/485, software selectable
 1 x RS232
 1 x RS232/CAN, software selectable
Available Modes : RS232
 RS422 full duplex
 RS485 4-wire, full duplex
 RS485 2-wire, half duplex, with echo
 RS485 2-wire, half duplex, without echo
Signals RS232 : TxD,RxD, RTS,CTS, DTR,DSR, DCD, RI, GND
Signals RS422 : Tx+/-, Rx+/-, GND
Signals RS485 2 Wire : Data+/-, GND
Signals RS485 4 Wire : Tx+/-, Rx+/-, GND
RS485 Data Direction Control : By ART (Automatic Receive Transmit control) or by RTS
Speed : RS232: up to 921.6 kbps, RS422/485: up to 3.6 Mbps

CAN Bus

Speed : CAN High Speed up to 1Mbit/s for transmit/receive
Signals : CAN_H, CAN_L, CAN_GND (shared with serial port 4)
Controller : SJA1000 Philips
Transceiver: TJA1050 Philips

LEDs

System : Power (red), WLAN (blue), IDE (yellow), User (green)
LAN : 10M/Link, 100M/Link x 2 integrated in RJ45 connector
Serial : TxD, RxD for each port
CAN : CAN Activity(Data), CAN Error(Shared with serial port 4)

Power Requirements

Power Input : 9 - 30V DC input
Consumption : Max. 1.5A @12V
Connector type : 3-pin Power Terminal block

Mechanical

Dimensions : 200×106×53 mm³ (W×L×H)
 210×112×53 mm³ including DB9 connectors and Terminal block
Weight : 0.38kg
Construction Material : Aluminium, 1mm
Mounting : DIN Rail, Wall mounting

Environmental

Operating Temp. : -10°C - 65°C
Storage Temp. : -20°C - 85°C

Approvals

EMC : FCC Class A, CE Class A
Environment : RoHS

Appearance

Alena Top View

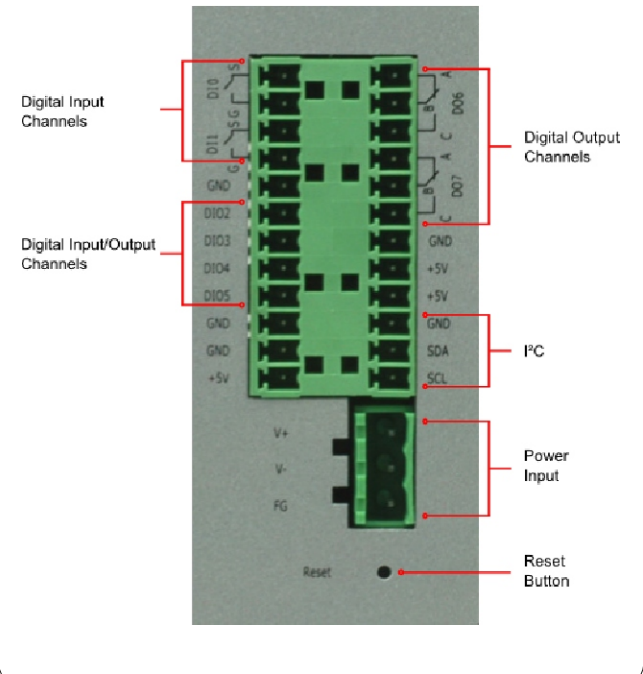

Software Specifications ■ ■ ■ ■ ■ ■ ■ ■ ■ ■

Software

Linux : Debian GNU/Linux for ARM
Kernel : 2.6
 Enhanced support for USB
 Watchdog Timer supported

Bootloader :
 Proprietary BIOS to install and boot OS from C/F, microSD, USB Mass Storage Devices or over Network

File System :
 JFFS2 (on-board flash), ext2 (preinstalled system on C/F) and many more choices

Protocol Stacks :
 ARP, PPP, CHAP, PAP, IPv4, ICMP, TCP, UDP, DHCP, FTP, SFTP, SNMP V1/V3, HTTP, HTTPS, NTP, NFS, SMB, SMTP, POP3, IMAP4, SSH 1.0/2.0, SSL, Telnet, PPPoE, OpenVPN, RFC2217

System Utilities :
 bash, telnet, ping, ftp, ssh, scp, netcat, socat, vim-tiny, e2progs, reiserfs, fdisk

Supporting Services & Daemons :
 Telnetd: Telnet server daemon
 vsftpd: FTP server daemon
 sshd: Secure shell server daemon
 Apache2: Web server daemon
 Courier: Mail server daemon
 Samba: windows share daemon
 sreddird: RFC2217
 pppd: dial in/out over serial port daemon
 openssl: Open SSL
 openvpn: virtual private network

Complete Image :
 Pre-configured OS installed on 2GB microSD, with software already installed. It consists of tools gcc-3.3, vim-tiny, services ssh, telnet, vsftpd (each as server and client), netcat and socat.

To speed up the boot process other software packages are not started automatically. To enable them please read the manual. Packages are:
 Samba client and server
 Apache2 web server
 Courier mail server
 NTP client and server
 sreddird RFC2217 server
 WindowMaker desktop
 xdm server (X11)
 AbiWord
 Dillo web browser

Software Development

On-board Tool Chain : Gcc, Glibc, gdb, vim-tiny editor, Gmake (develop on Alena)

Linux Tool Chain : Gcc, Glibc, gdb, Insight, gmake (develop on a Linux PC)

Kernel : Kernel 2.6 sources

Hardware : Driver sources for Alena-specific hardware components

Device Drivers

Data Communication :
 USB (supports USB Mass Storage Devices, USB-to-Serial converters, USB-CAN adapter, Bluetooth)
 UART 16C950, 128 Byte FIFO, RS232/422/485
 I²C
 WLAN 802.11b/g RaLink cards (RT2561) optional
CAN : VScom CAN API, CANFestival, CANopen, LinCAN
Others : Digital I/O, RTC, Buzzer, LEDs, Watchdog Timer

Ordering Information ■ ■ ■ ■ ■ ■ ■ ■ ■ ■

Art.No : 6805
Product Name : OpenRISC - Alena
Packing list :
 . OpenRISC Alena
 . Power supply adapter 12V, 1500mA
 . Adapter cable for console port
 . DVD-ROM-1: Debian on ARM
 . DVD-ROM-2: system images, sources, tools, English documentation

Where to buy?

VSCOM's global distributor can help you find the right product for your requirements.

or contact VSCOM directly:

sales@vsc.com.de

www.vsc.com.de

VScom is offering a full range of serial communication solutions for industrial application fields. Currently VScom designs and manufactures technologically advanced and cost effective Ethernet to Serial, USB to Serial and PCI to Serial solutions. Envisioning the rapid growth in using Ethernet in different industrial fields, VScom is presently focusing on intergration of LAN and Wireless LAN technology in serial connectivity products. VScom brand products have been in the market since 1995 and are known as high quality, reliable and long life devices. More information on the products are available at www.vsc.com.de

